

Twist-Set Controls

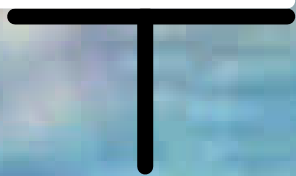

2004
Catalogue



**Global Valves
and Engineering**

"your partner for the future"



Tel: (02) 9868 5055

Tel: (02) 9868 5063

Email: sales@globalvalves.com.au

Website: www.globalvalves.com.au



EASY SET
COLOUR CODED CAM

PROXIMITY
SENSORS



MECHANICAL
SWITCHES

ANALOGUE POSITION
TRANSMITTER

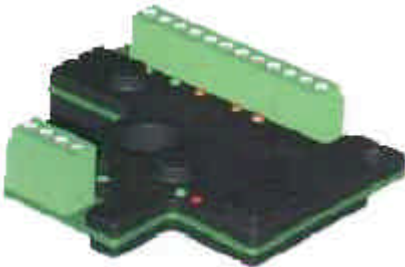
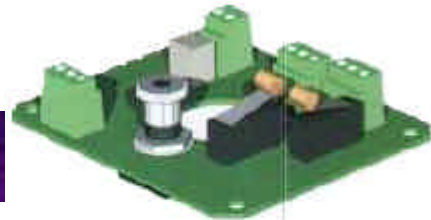

FULLY ENCAPSULATED
ASI CARD

INTERNAL SOLENOID
PILOT

M12 PLUG &
SOCKET

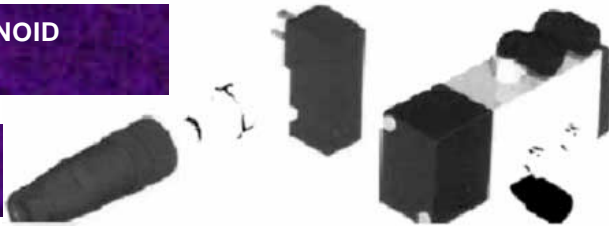

INTEGRAL
SOLENOID

Global Valves and Engineering Pty Ltd

"your partner for the future"

Tel: (02) 9868 5055 Fax: (02) 9868 5063 Email: sales@globalvalves.com.au Website: www.globalvalves.com.au

1100 SERIES
1200 SERIES

COMPOSITE WITH MECHANICAL SWITCHES
COMPOSITE WITH PROXIMITY SENSORS

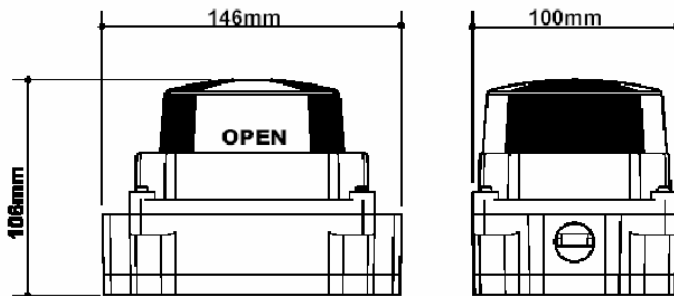

ALSO AVAILABLE IN VESTAMID

1300 SERIES
1400 SERIES

ATEX FLAME PROOF SWITCH BOX
ALUMINIUM SWITCH BOX WITH BEACON INDICATOR

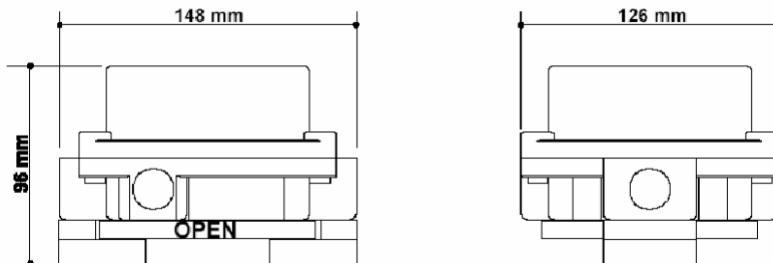

ALSO AVAILABLE IN STAINLESS STEEL

1500 SERIES
1600 SERIES

CONTROL STATION WITH INTEGRAL SOLENOID
CONTROL STATION WITH BUS COMMUNICATION CARD

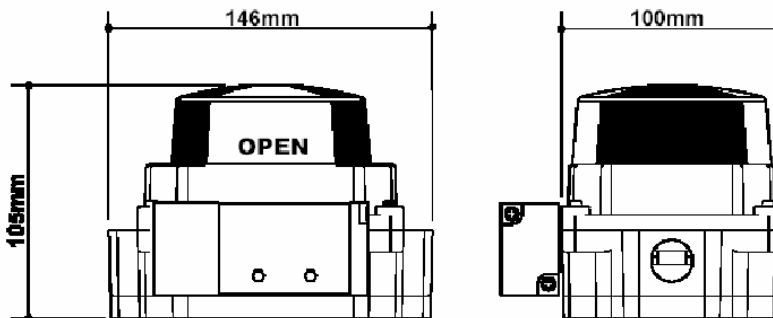

ALSO AVAILABLE IN STAINLESS STEEL

1800 SERIES
1900 SERIES

PUCK WITH PROXIMITY SENSORS
PUCK WITH AS-I BUS COMMUNICATION



Global Valves and Engineering Pty Ltd

"your partner for the future"

Tel: (02) 9868 5055 Fax: (02) 9868 5063 Email: sales@globalvalves.com.au Website: www.globalvalves.com.au

NAMUR SOLENOID VALVES

IP65, FLAME PROOF & INTRINSICALLY SAFE

5 port 2 position single coil
5 port 2 position double coil
5 port 3 position

Flow Rate: 1680 l/min @ 6 Bar
Ports: 1/4" BSP (NPT Optional)
Pressure range: 1.5 to 8 bar
Maximum pressure: 10 bar
Voltages: 12, 24, 48 & 110 VDC
24, 48, 110 & 220 VAC



MAINFOLD SOLENOID VALVES



IP65, FLAME PROOF & INTRINSICALLY SAFE

5 port 2 position single coil
5 port 2 position double coil
5 port 3 position

Size: 1/8" to 1/2"
Ports: BSP (NPT Optional)
Pressure range: 1.5 to 8 bar
Maximum pressure: 10 bar
Voltages: 12, 24, 48 & 110 VDC
24, 48, 110 & 220 VAC

PROXIMITY SENSORS

IP67 & INTRINSICALLY SAFE

Output: PNP or NPN
NAMUR (I/S)
AC & DC two wire
Size: M12 to M30
with Plug & Socket



LINEAR MOUNTING KITS



VALVE TYPES

- Globe Valves
- Diaphragm Valves
- Control Valves
- Knife Gate Valves
- Gate Valves
- Pinch Valves

Global Valves and Engineering Pty Ltd

"your partner for the future"

Tel: (02) 9868 5055 Fax: (02) 9868 5063 Email: sales@globalvalves.com.au Website: www.globalvalves.com.au