

# STAINLESS STEEL BALL VALVE

2-PIECE FULL BORE

SIZE RANGE 8mm-100mm

BSP Ends



Suitable for Isolating duties in General Industrial Applications, Oil Pipelines, Hot Water Services, Condensate Lines, Water Treatment, HVAC, Mining, W.W.T.P. Applications, Gauge and Instrument Isolation

## FEATURES

- Full bore
- Actuator / limit switch mounting pad
- Blow-out proof stem
- 304ss lever with PVC grip
- Investment casting body and cap
- Stainless steel components

## OPTIONS

- Fig. V1-WCB (WCB steel body)
- Fig. V1-NPT (with NPT ends)
- Fig. V3 (3 piece full bore)
- Pneumatic or electric actuation

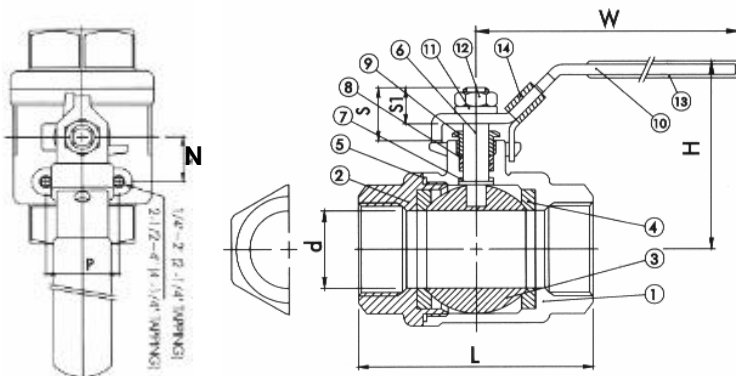

Fig. V2



## COMPONENT MATERIAL

COMPONENT	MATERIAL
BODY	ASTM-A351-CF8M
CAP	ASTM-A351-CF8M
BALL	ASTM-A351-CF8M
SEAT	15% R-P.T.F.E.
STEM SEAL	P.T.F.E.
LEVER	AISI 304
LOCK DEVICE	AISI 304

## DIMENSIONS

SIZE mm	8	10	15	20	25	32	40	50	65	80	100
L	44.5	44.5	57.0	65.0	76.0	87.5	102.0	123.0	156.0	184.0	250.0
H	51.0	51.0	53.0	59.5	73.0	79.0	90.5	98.5	130.5	142.5	173.5
W	95	95	95	110	135	135	165	165	215	215	325
N	12.5	12.5	12.5	21.0	22.5	23.5	23.5	23.5	35.0	35.0	50.0
MAX kPa@ 50°C	9,000	9,000	9,000	9,000	9,000	8,400	8,400	8,400	8,400	7,300	7,300
BORE $\phi$	11.6	12.7	15	20	25	32	38	50	65	80	100
CV	6.6	7.9	11.2	21.0	35.0	57.0	80.0	148.0	265.0	415.0	780.0

Data Sheet BL-V2-Rev01

For installation, operation and maintenance refer to I.O.M.

Details subject to change

**Global Valves and Engineering Pty Ltd**

*"your partner for the future"*

Tel: (02) 9868 5055 Fax: (02) 9868 5063 Email: sales@globalvalves.com.au Website: www.globalvalves.com.au